

# **General Information On Handling and Maintenance Of 25kV to 72.5kV Dry Type Bushings**



## Foreword

*This guide is intended to address issues strictly relating to ECI cycloaliphatic epoxy resin, dry type bushings for use on transformers, circuit breakers and reclosers. Issues relating to any other ECI product should be addressed with ECI Technical staff.*

*These guidelines are presented as suggestions only and are not intended to reflect the specific conditions of our product's usage on your equipment. As such, we recommend that you use this information carefully and take the necessary steps to ensure that it accommodates your particular application and operating conditions. The reader is requested to address any questions or concerns directly with ECI technical staff for further information and instructions on proper installation, use and maintenance of our bushings.*

*ECI makes no warranty, representations, whether express or implied, or representation and assumes no liability for the accuracy of the information in this document or the use of such information. All information contained in this guide is subject to change without prior notice. PLEASE REFER TO THE DISCLAIMER OF WARRANTIES AND LIMITATION OF LIABILITY at the end of this document.*

This guide is intended to provide the user with information concerning the handling and maintenance of ECI polymeric bushings, from the time the bushings are received until they are put into service, as well as general maintenance guidelines after specific in-service periods. All possible contingencies, which may arise during installation, operation, or maintenance, and all details and variations of this equipment, are not purported to be covered in this guide. For any questions that may arise and not covered by this guide, the reader is recommended to contact ECI for assistance.

## GENERAL BUSHING INFORMATION

ECI Dry Type bushings are designed for use on transformers and oil circuit breaker applications, up to 72.5kV phase-to-ground voltage class and 5000A current rating. Bushings can be designed to conform to the following bushing standards:

- IEC 60137: Insulated Bushings for Alternating Voltages Above 1000V
- ANSI/IEEE C57.19.01: Standard Performance Characteristics and Dimensions for Outdoor Apparatus Bushings
- ANSI/IEEE C57.19.00: Standard General Requirements and Test Procedure for Outdoor Power Apparatus Bushings
- CAN/CSA C88.1: Power Transformer and Reactor Bushings

(Please refer to the bushing drawing for the applicable standard)

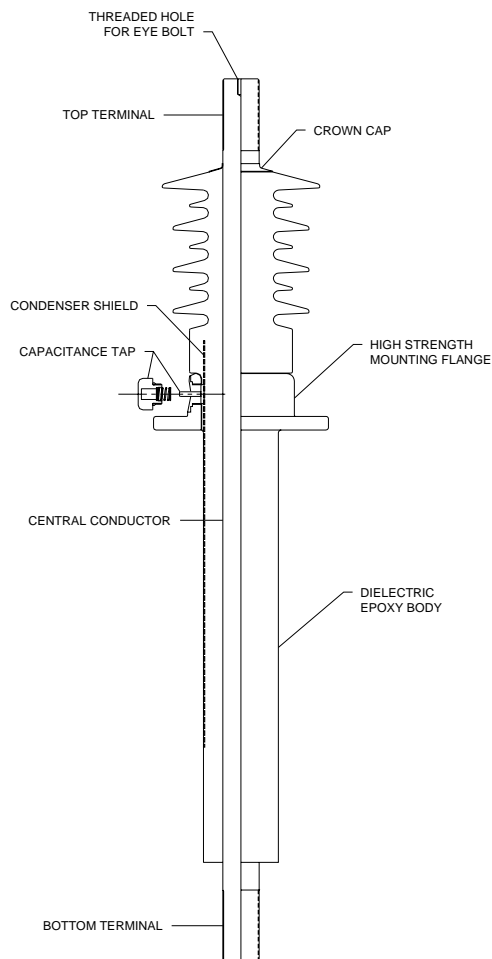

ECI bushings consist of a central electrolytic copper conductor, either solid core or drawlead type, encapsulated in a monolithic solid rigid cycloaliphatic epoxy resin dielectric body. A high strength aluminum flange is bonded to the epoxy body and allows for mounting. All working surfaces are precision machined for optimal fit. The flange is designed to insure maximum seal – with no leakage permitted between the flange and the epoxy body. A non-foil condenser shield is cast into the resin along with the conductor, providing necessary E-Field grading and distribution. In the case of oil circuit breaker type bushings, the condenser shield is permanently connected to the metallic flange via a setscrew insuring shield grounding. In the case of transformer type bushings, a capacitance tap connection is supplied. The shield is accessible through a welded solid pin, insulated from the flange when the capacitance tap button is removed, allowing for capacitance and power factor measurements.

There is no oil or other fluids or gases used in the construction of ECI bushings.

This document does not purport to provide safe practice practices for use of equipment or the performance of work around equipment where ECI bushings are installed. Installation and maintenance of ECI bushings is to be carried out by trained, certified and approved personnel only. Although ECI bushings present no danger to personnel when not energized, reasonable care is to be taken when handling and transporting bushings. Some edges may be sharp and bushings are bulky and heavy.

## **SHIPPING**

ECI bushings are shipped in plywood crates, supported at two or three points, depending on the model. Bushings are shipped horizontally.

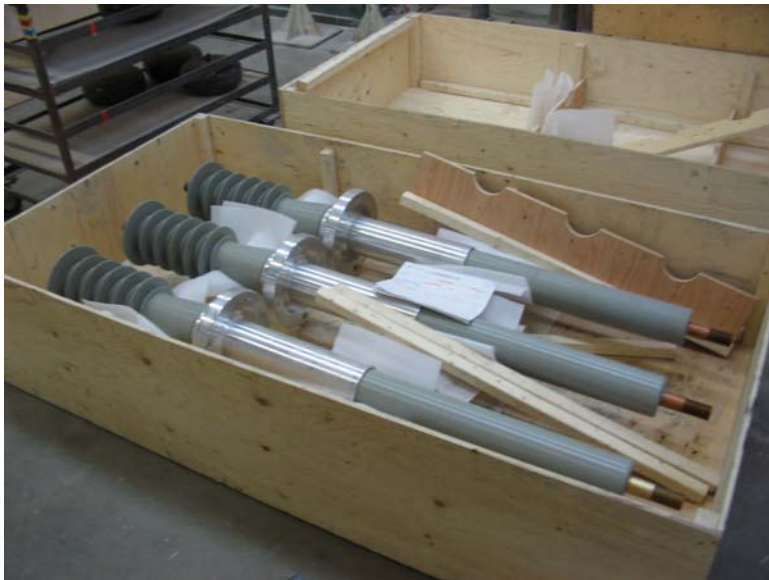

As ECI bushings are dry type (no oil or any other fluid components within the bushing construction), no special provisions are given for their shipping and storage other than given in this guide. Therefore, they can be stored in their shipping .

When returning bushings to ECI, please use the same crating and strapping methods as when they were shipped originally.

## **RECEIVING**

Bushing crates are constructed with provisions for handling with forklift equipment. Insure for sufficient support of crate, as weight distribution within the crate is not balanced. Reasonable care should be taken when opening the crate so as not to accidentally damage the bushing. Crates are usually assembled with wood screws.

Inspect crate and bushing(s) carefully for any signs of damage that may have occurred during transport. Visually inspect each bushing for any signs of impact, cracks, loose components or abnormal surface conditions.

Bushing routine test reports should be included with the shipping documents within the crate. Please insure that the test documents match the bushings as indicated on the bushing nameplates located on the flange. **IN THE EVENT OF A MISMATCH, QUARANTINE THE BUSHINGS AND CONTACT YOUR ECI REPRESENTATIVE IMMEDIATELY. DO NOT INSTALL THE BUSHINGS UNDER ANY CIRCUMSTANCES.**

## **STORAGE**

We recommend storing ECI bushings indoors, in dry and normal room temperature conditions. However, if necessary, ECI bushings can be stored outdoors (temperature range from  $-40^{\circ}\text{C}$  to  $60^{\circ}\text{C}$ ) if properly covered to maintain dryness. Please contact ECI technical staff for outdoor storage recommendations.

## **HANDLING**

The bushing can be removed from the crate by several means. The preferred and recommended method consists of using an eyebolt threaded into the central copper conductor at the top end termination. Insure the eyebolt is fully threaded into the hole and tightened accordingly. Alternatively, an anchor shackle with the shackle pin attached through a flange mounting hole can be used. As a last resort, a non-metallic choker rope or sling can be strapped under the top shed to lift the bushing. Handle the bushing with care and take all necessary precautions to prevent it from falling or bumping into surrounding objects. Do not subject the bushing to sudden shocks. Slowly take up the slack in the attachment, and then raise the bushing at a constant and steady rate.

## **INSTALLATION**

Before installation, remove all wrapping material and foreign particles from the bushing. Clean the conductor end terminal threads, aluminum flange seat and wipe clean the epoxy (grey color) insulation with a dry clean cloth (both ends). The lower insulation end can also be thoroughly cleaned with a clean cloth and isopropyl alcohol to remove any trace oil or grease that may be present.

We recommend performing the capacitance and power factor tests prior to energizing the bushing. Remove the bushing from its crate and clean beforehand. Refer to the Doble M400 Test set instructions, the Doble Bushing Field Test and our Routine Test Report for the measured values (these should match the values indicated on the bushing name plate). Bushings can be tested immediately after removal from the crate. Discrepancies between the measured values and the indicated values on the name plate can occur since nameplate values are obtained under controlled conditions at the factory. Values measured at receiving should be used as a baseline to compare with future field measurements. Contact ECI for corrective action if the power factor exceeds 0.01, and/or if the capacitance varies more than  $\pm 10\%$  of the original value.

ECI bushings can be installed at any angle. A proper gasket is required between the flange and the equipment. In case of mounting problems, contact ECI for further corrective action. Do not for any reason modify or alter any part of the bushing, including the aluminum flange.

When bolting the bushing to the equipment, tighten each bolt no more than a half turn at a time. Follow a criss-crossing bolt tightening sequence as shown in the figure below.

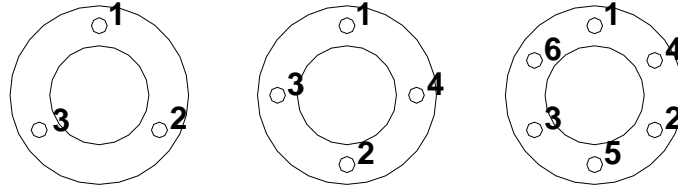

By using the proper tightening torque for the bolt size used and the tightening sequence provided, flange damage and sealing problems from improper tightening and uneven pressure on the gasket can be avoided. The use of a calibrated torque wrench is recommended.

Before tightening, insure that the conductor terminal ends are free to move since as the flange is tightened, a small displacement at the flange will cause a much larger displacement at the terminal ends. Potential damage to the bushing and equipment is possible if this is not done.

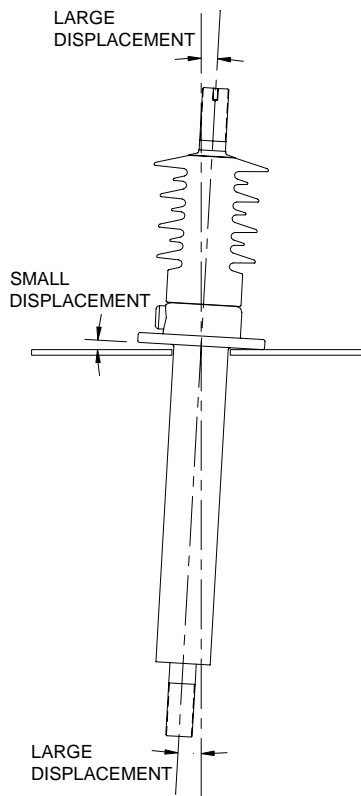

## CAPACITANCE TEST TAP

The capacitance test tap is used for capacitance and power factor measurements. **INSURE BUSHING IS NOT ENERGIZED PRIOR TO MEASUREMENT.** The test tap is located on the bushing mounting flange. Generally, capacitance test taps are supplied only with transformer bushings. However, some users request them to be supplied with oil circuit breaker bushings as well. For measurement taking, unscrew the capacitance tap button, carefully removing it with the contact spring, exposing the contact pin. Once measurements are done, replace the button and tighten by hand.

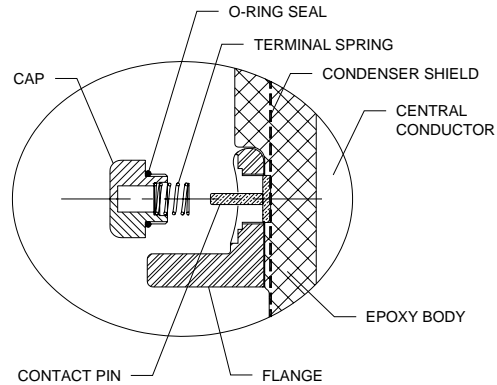

## NAMEPLATE

Every bushing is supplied with a nameplate located on the mounting flange. Nameplate data will provide all pertinent information relevant to the bushing: manufacturer name and address, model number, serial number, voltage class, current rating, BIL, C1 and PF (or  $\tan \delta$ ). When requesting information concerning a specific bushing, please be sure to provide at a minimum the model number and serial number.

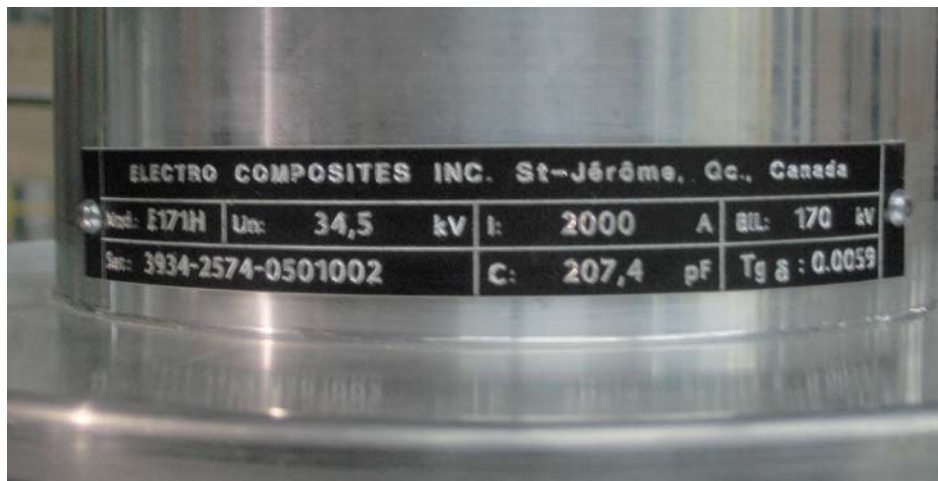

## **MAINTENANCE**

ECl bushings are designed for outdoor, severe condition service with minimal maintenance requirements. However, bushings exposed to salt spray, cement dust or other abnormal deposits must be cleaned regularly to prevent flashover and corrosion of metal parts. Cleaning should be done before performing routine power factor and capacitance measurements (bushings with a capacitance tap only).

### **AFTER 1 MONTH OF SERVICE AND YEARLY**

Check the bushing insulation (epoxy part) for signs of cracks or chips and surface contamination deposits. Should treeing be visible, clean the affected area with isopropyl alcohol. Insure all connectors are tight and there are no loose components. Inspect the bushing with an IR camera to determine if there is a hot spot, which would be indicative of a bad or loose connection.

### **ONCE EVERY 3 TO 5 YEARS**

Perform the yearly maintenance check and cleaning. Perform a Doble test for Power Factor and Capacitance. Refer to the Doble M-4000 test set instructions, Doble Bushing Field Test Guide, and ECl instructions for proper test procedures. Refer to values measured at bushing receiving for baseline value. See INSTALLATION section in this document.

### **FIELD REPAIRS**

Any damage to a bushing, which might make repair either desirable or necessary, should be reported to ECl. Typically, a small chip at the end of a shed will have very little effect on the bushing's function. Do not try to fill chips with epoxy, as this will have no beneficial effects. Since the bushing insulation is essentially a solid epoxy casting, chips in the insulation surface will not cause any moisture problems. Should a crack be found, DO NOT ATTEMPT TO REPAIR THE BUSHING AND NOTIFY ECl IMMEDIATELY.

**DISCLAIMER OF WARRANTIES  
AND LIMITATION OF LIABILITY**

THERE ARE NO UNDERSTANDINGS, AGREEMENTS, REPRESENTATIONS OR WARRANTIES, EXPRESSED OR IMPLIED, INCLUDING WARRANTIES OF MERCHANTABILITY OR FITNESS FOR A PARTICULAR PURPOSE OTHER THAN THOSE SPECIFICALLY SET OUT IN AN EXISTING CONTRACT BETWEEN THE PARTIES. ANY SUCH CONTRACT STATES THE ENTIRE OBLIGATION OF SELLER. THE CONTENTS OF THIS DOCUMENT SHALL NOT BECOME PART OF OR MODIFY ANY PRIOR OR EXISTING AGREEMENT, COMMITMENT OF RELATIONSHIP.

THE INFORMATION, RECOMMENDATIONS, DESCRIPTION AND SAFETY NOTATIONS IN THIS DOCUMENT SHOULD NOT BE CONSIDERED TO BE ALL INCLUSIVE OR COVERING ALL CONTINGENCIES. IF FURTHER INFORMATION IS REQUIRED, ECI SHOULD BE CONSULTED.

**NO WARRANTIES, EXPRESSED OR IMPLIED, INCLUDING WARRANTIES OF FITNESS FOR A PARTICULAR PURPOSE OR MERCHANTABILITY, OR WARRANTIES ARISING FROM COURSE OF DEALING OR USAGE OF TRADE, ARE MADE REGARDING THE INFORMATION, RECOMMENDATIONS, DESCRIPTIONS, AND SAFETY NOTATIONS CONTAINED HEREIN. IN NO EVENT WILL ECI BE RESPONSIBLE TO THE USER IN CONTRACT, IN TORT (INCLUDING NEGLIGENCE), STRICT LIABILITY OR OTHERWISE FOR ANY SPECIAL, INDIRECT, INCIDENTAL, OR CONSEQUENTIAL DAMAGE OR LOSS WHATSOEVER INCLUDING BUT NOT LIMITED TO DAMAGE TO OR LOSS OF USE OF EQUIPMENT, PLANT OR POWER SYSTEM, COST OF CAPITAL, LOSS OF PROFITS OR REVENUES, COST OF REPLACEMENT POWER, ADDITIONAL EXPENSES IN THE USE OF EXISTING POWER FACILITIES, OR CLAIMS AGAINST THE USER BY ITS CUSTOMERS RESULTING FROM THE USE OF THE INFORMATION, RECOMMENDATIONS, DESCRIPTIONS, AND SAFETY NOTATIONS CONTAINED HEREIN.**